

Brake Pole Module Replacement for Magstop Clutch Brakes

P-1428
819-0394

Replacement Instructions

⚠ WARNING Failure to follow these instructions may result in product damage, equipment damage, and serious or fatal injury to personnel.

1. Turn engine off and remove key to prevent accidental starting of engine and possible injury.
2. Remove clutch from tractor.
3. Use right angle grinder or suitable substitute to grind off 5 (five) rivet heads from brake pole pads. Do not grind on field shell side of rivets, unless rivets cannot be removed by grinding on the brake pole side of clutch. (See Figure 1)

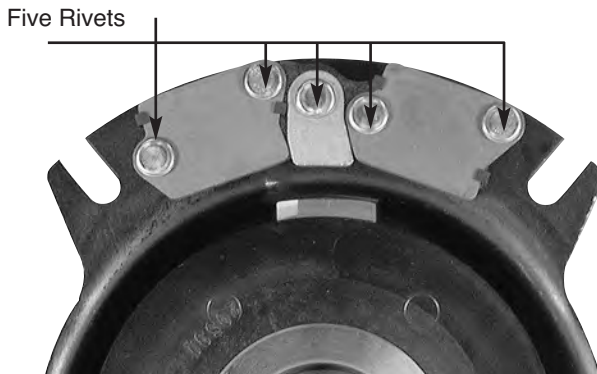

Figure 1

4. Use appropriate sized punch to drive rivet from factory brake components. Discard old brake components. (See Figure 2)

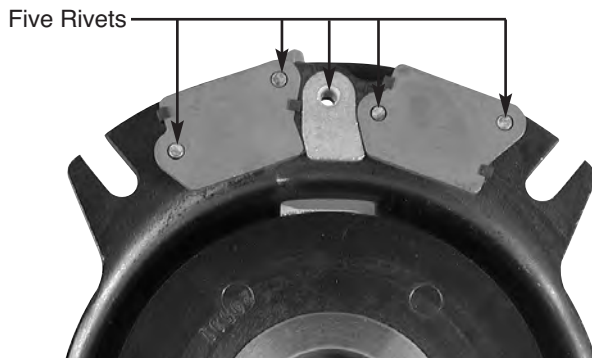

Figure 2

5. Magnets are marked with a white dot on face that should contact clutch brim. Replace old components with new brake pole components: 2 brake poles & 2 magnets, mid pole, 5 nuts and 5 bolts. (See Figure 3) Install with bolt, nut and lockwasher. Tighten bolts by hand, and then tighten bolts evenly with wrench.

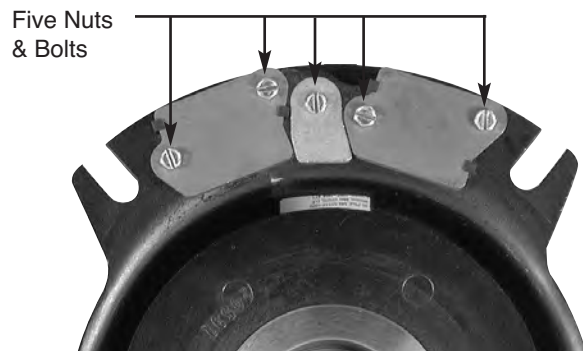

Figure 3

6. Torque brake module mounting bolts to specified value of 20 in.lb. plus or minus 1 in.lb. (See Figure 4)



Figure 4

7. Reinstall clutch per owner's manual, care should be taken so that anti-rotation device does not bind the clutch. Torque mounting bolt to specified torque. 50-55 ft.lbs. for 7/16" bolt, and 42-45 ft.lbs. for 3/8" bolt (Grade 8).
8. Reconnect power leads to clutch.
9. Burnish the brake poles by cycling the clutch about ten times at full engine rpm, letting load brake to full stop and accelerating to full rpm on each cycle. Cycle rate should be approximately 20 seconds on and 20 seconds off.

Warranty

Warner Electric LLC warrants that it will repair or replace (whichever it deems advisable) any product manufactured and sold by it which proves to be defective in material or workmanship within a period of one (1) year from the date of original purchase for consumer, commercial or industrial use.

This warranty extends only to the original purchaser and is not transferable or assignable without Warner Electric LLC's prior consent.

Warranty service can be obtained in the U.S.A. by returning any defective product, transportation charges prepaid, to the appropriate Warner Electric LLC factory. Additional warranty information may be obtained by writing the Customer Satisfaction Department, Warner Electric LLC, 449 Gardner Street, South Beloit, Illinois 61080, or by calling 815-389-3771.

A purchase receipt or other proof of original purchase will be required before warranty service is rendered. If found defective under the terms of this warranty, repair or replacement will be made, without charge, together with a refund for transportation costs. If found not to be defective, you will be notified and, with your consent, the item will be repaired or replaced and returned to you at your expense.

This warranty covers normal use and does not cover damage or defect which results from alteration, accident, neglect, or improper installation, operation, or maintenance.

Some states do not allow limitation on how long an implied warranty lasts, so the above limitation may not apply to you.

Warner Electric LLC's obligation under this warranty is limited to the repair or replacement of the defective product and in no event shall Warner Electric LLC be liable for consequential, indirect, or incidental damages of any kind incurred by reason of the manufacture, sale or use of any defective product. Warner Electric LLC neither assumes nor authorizes any other person to give any other warranty or to assume any other obligation or liability on its behalf.

WITH RESPECT TO CONSUMER USE OF THE PRODUCT, ANY IMPLIED WARRANTIES WHICH THE CONSUMER MAY HAVE ARE LIMITED IN DURATION TO ONE YEAR FROM THE DATE OF ORIGINAL CONSUMER PURCHASE. WITH RESPECT TO COMMERCIAL AND INDUSTRIAL USES OF THE PRODUCT, THE FOREGOING WARRANTY IS IN LIEU OF AND EXCLUDES ALL OTHER WARRANTIES, WHETHER EXPRESSED OR IMPLIED BY OPERATION OF LAW OR OTHERWISE, INCLUDING, BUT NOT LIMITED TO, ANY IMPLIED WARRANTIES OF MERCHANTABILITY OR FITNESS.

Some states do not allow the exclusion or limitation of incidental or consequential damages, so the above limitation or exclusion may not apply to you. This warranty gives you specific legal rights and you may also have other rights which vary from state to state.

Changes in Dimensions and Specifications

All dimensions and specifications shown in Warner Electric catalogs are subject to change without notice. Weights do not include weight of boxing for shipment. Certified prints will be furnished without charge on request to Warner Electric.



Warner Electric LLC
449 Gardner Street • South Beloit, IL 61080
815-389-3771 • Fax: 815-389-2582
www.warnerelectric.com
An Altra Industrial Motion Company